

STATE OF NEVADA  
 CERTIFICATE OF MINING LOCATION  
 LODE CLAIM ON PUBLIC DOMAIN

75572

NOTICE IS HEREBY GIVEN that the Twin No. 44 lode mining claim has been located by AMERICAN SELCO INC. a New York corporation, whose address is 90 West Grove Street, Suite 100, Reno, Nevada 89509. The general course of this claim is North/South. This claim is 1500 feet in length along the course of the claim, being 1490 feet from the point of discovery in a North direction to the North end line of this claim, and 10 feet in a South direction to the South end line of the claim. This claim is 600 feet in width, being 300 feet in width on each side of the center line of the claim.

This claim is located within the N/E Quarter of Section 36, Township 19 North, Range 49 East, Mount Diablo Base and Meridian, unknown Mining District, Eureka County, Nevada. The location monument of this claim is situated with reference to some natural object or permanent monument as follows: Corner no. 1 of this claim is located approximately 6200 feet N 43° E from the located SW corner section 36 T19N R49E MDM

The corners of this claim are marked by 4"x4" posts or 4" trees with metal tags inscribed with the appropriate corner number as shown on the following sketch and the accompanying claim map.

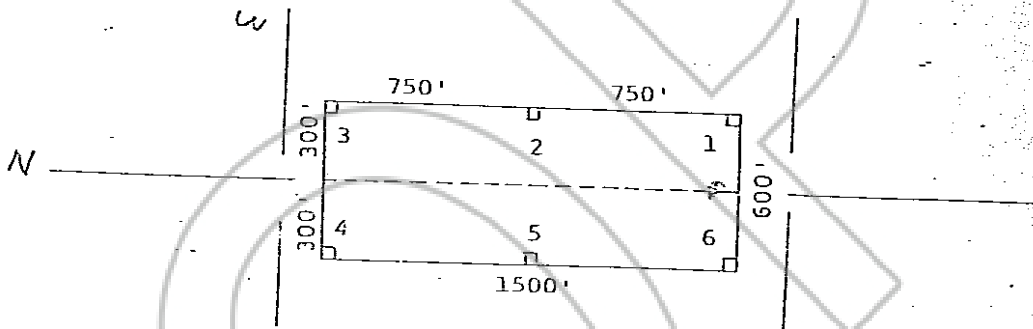

The location work consisted of making the maps as provided in NRS 517.040.

Dated and posted on the ground this 28 day of May, 19 80

Witnesses:

Locator:

AMERICAN SELCO INC.

By [Signature]  
 Agent for  
 American Selco Inc.

STATE OF NEVADA )  
 ) ss.  
 COUNTY OF \_\_\_\_\_ )

I hereby certify that the within instrument was filed and recorded at the request of: \_\_\_\_\_  
 FILE NO. \_\_\_\_\_  
 on \_\_\_\_\_  
 at \_\_\_\_\_  
 Docket \_\_\_\_\_ Page \_\_\_\_\_

RECORDED AT REQUEST OF  
 American Selco Inc.  
 BOOK 85 PAGE 231  
 80 AUG 22 11:27  
 OFFICE OF THE CLERK  
 EUREKA COUNTY, NEVADA  
 WILLIS A. DEWITT, CLERK  
 FILE NO. 75572  
 Fee: \$ 3.00