

**81647 STATE OF NEVADA  
LOCATION CERTIFICATE  
Lode Claim on Public Domain**

KNOW ALL MEN BY THESE PRESENTS, That Al Holmes & Assoc. Inc., Agent for Freeport Exploration Co., has located the Poach #27 Lode Mining Claim situated on land belonging to the United States of America.

This claim is located within the following section(s):  
SE of sec. 35, T. 17N, R. 48 E;  
 of sec. \_\_\_\_\_, T. \_\_\_\_\_, R. \_\_\_\_\_;  
 of sec. \_\_\_\_\_, T. \_\_\_\_\_, R. \_\_\_\_\_;  
 of sec. \_\_\_\_\_, T. \_\_\_\_\_, R. \_\_\_\_\_;  
 Mt. Diablo Base & Meridian, Eureka County, Nevada.

The locator(s), by this certificate, along with the right of discovery and location, claim 1500 feet, linear and horizontal measurement along the vein thereof, with all its dips, angles, and variations as allowed by law, together with 300 feet on each side of the middle of said vein at the surface and all veins, lodes, ledges, deposits, and surface ground within the lines of said claim with the discovery being 10 feet south of the north end center. The general course of this claim being north to south and is described by metes and bounds as follows:

- Beginning at corner # 1, the northwest corner.
- Thence East 600 feet to corner #2.
- Thence South 750 feet to corner #3.
- Thence South 750 feet to corner #4.
- Thence West 600 feet to corner #5.
- Thence North 750 feet to corner #6.
- Thence North 750 feet to corner #1, the point of beginning.

Corner # 1 is tied to a Government Monument as follows: Beginning at section corner 11|12 14|13, T 16 N, R48 E, M.D.B.M., a USGS Brass Cap, thence 1783.5 feet west and 12,945.1 feet north to said corner #1.

The location work consisted of making maps as provided in NRS 517.040. All corner monuments are 4" dia. white PVC - 5' long with metal tags inscribed with the appropriate corner.

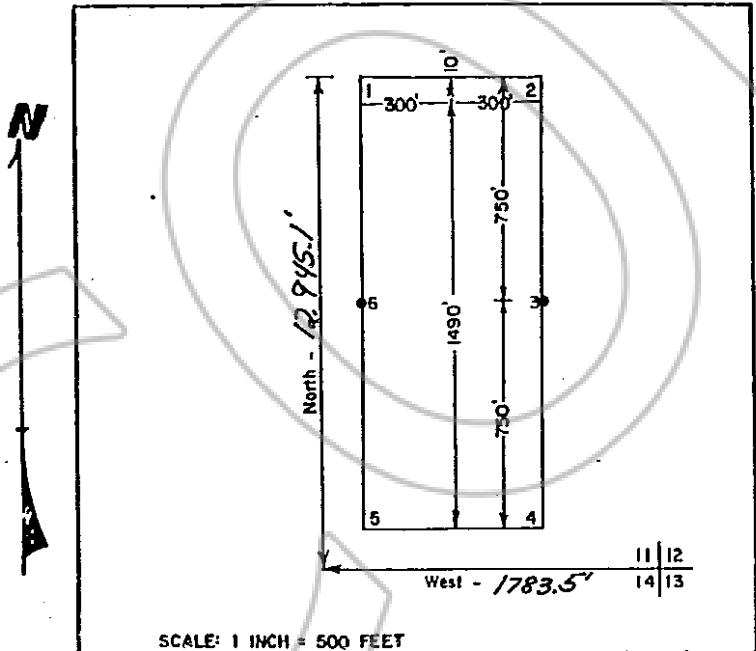

RECORDER'S STAMP  
 RECORDED AT REQUEST OF  
**FREEPORT EXPL CO**  
 BOOK 97 PAGE 336

81 AUG 28 9:58

OFFICIAL RECORDS  
 EUREKA COUNTY, NEVADA  
 WILLIS A. DEPAOLI-RECORDER  
 FILE NO. 81647  
 FEE \$ 4.00

Said lode discovered on June 7, 1981.

Said lode posted on June 7, 1981.

Located by: Freeport Exploration Co.  
 P. O. Box 1941  
 Reno, Nevada 89505

Mary Ann Bannua, of  
Al Holmes & Associates Inc.

Witness

BOOK 97 PAGE 236