

153156

COUNTY TREASURER'S DELINQUENT TAX DEED

THIS INDENTURE, made this 1st day of June, 1994, by and between JOAN SHANGLE, County Treasurer, in and for the County of Eureka, State of Nevada, acting as such Treasurer in conformity with the laws under N.R.S. 361.590, GRANTOR, and JOAN SHANGLE, County Treasurer and Ex-Officio Tax receiver in and for the County of Eureka, State of Nevada, acting as such trustee in this matter, in conformity with the provisions of N.R.S. 361.590, GRANTEE:

WITNESSETH:

That the grantor, for a consideration of the covenants and agreements herein specified, does by these presents grant, bargain, sell, and convey unto the grantee, and her successors in office, and assigns, the following described properties as appear on record upon the Assessment Roll of Eureka County, State of Nevada, for taxable year 1991-1992, and entered by the County Assessor as follows, to-wit:

Roll No. 280

Denise Jari Bartlett  
c/o Mary Andrus  
Parcel 02-026-04  
Lot 3, Block 3, C. V. R. & F. Unit #1  
Valuation \$930  
Tax \$16.70

Roll No. 438

Samuel E. & Lottie Burkholder  
c/o Everett W. Jinks  
Parcel 03-083-04  
Lot 6, Block 11 C. V. R. & F. Unit #4  
Consisting of approximately 4.77 acres  
Valuation \$1,090  
Tax \$17.82

Roll No. 726

R. P. Chisolm  
Parcel 03-103-01  
Lot 4, Block 15 C. V. R. & F. Unit #4  
Consisting of approximately 4.34 acres  
Valuation \$990  
Tax \$16.20

Roll No. 833  
 Daily Trust, Timothy E. & Rose C.  
 c/o Kathryn L. Murphy, Tr.  
 Parcel 05-020-29  
 W½NE¼ Section 33, T31N, R48E M.D.B.&M.  
 Consisting of approximately 80 acres  
 Valuation \$4,060  
 Tax \$66.43

Roll No. 860  
 Lester V. Davis  
 c/o Mark Davis  
 Parcel 02-045-01  
 Lot 4 Block 34, C.V.R.&F. Unit #1  
 Consisting of approximately 2.07 acres  
 Valuation \$1,620  
 Tax \$29.06

Roll No. 1528  
 Nannie B. & Isom Hall  
 Parcel 05-050-06  
 SW¼NE¼ Section 29, T31N, R48E M.D.B.&M.  
 Consisting of approximately 10 acres  
 Valuation \$790  
 Tax \$12.93

Roll No. 1792  
 Gloria Kelly, Donald Wickham, Pearl Lawrence,  
 Betty Hill, Estelle Gallianne, Susan O'Brian,  
 Richard Terry  
 Parcel 05-080-26  
 SE½SE¼ Section 12, T31N, R49E M.D.B.&M.  
 Consisting of approximately 40 acres  
 Valuation \$2,140  
 Tax \$35.00

Roll No. 2501  
 Edward G. & Mattie Rasser  
 Parcel 03-196-04  
 SW½ Lot 56, Nevelco Inc. Unit #1  
 Consisting of approximately 3.47 acres  
 Valuation \$730  
 Tax \$11.94

Roll No. 2502  
 Edward G. & Mattie Rasser  
 Parcel 03-241-04  
 Lot 4 Block Y, Nevelco Inc. Unit #2  
 Valuation \$140  
 Tax \$2.28

Roll No. 2558  
 Kenneth M. Roberts  
 Parcel 05-420-18  
 NE½NE½SW¼ Section 1, T29N, R48E M.D.B.&M.  
 Consisting of approximately 8.14 acres  
 Valuation \$580  
 Tax \$9.50

Roll No. 2559  
 Kenneth M. Roberts  
 Parcel 03-379-02  
 Lots 1, 2, 10, 11, 12 Block 46, Walker  
 Villa Subdivision  
 Valuation \$660  
 Tax \$10.80

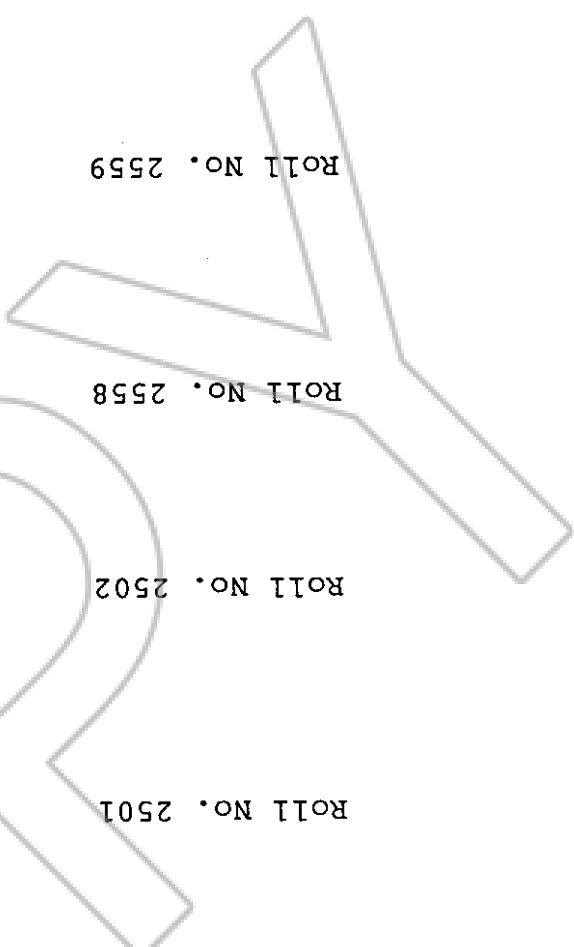

The above and foregoing described properties were assessed by the County of Eureka, State of Nevada, for the taxable year 1991-1992 in the names herein set out, the amount for taxes assessed and the amount due for the same as specified.

The Assessment Roll was delivered to the said County Treasurer for the purpose of receiving the taxes on the 1st day of July, 1991. The due and legal notice to the taxpayers was given by publication in The Eureka Sentinel, a newspaper published for circulation in the Town and County of Eureka, State of Nevada, and by notice forwarded by mail to the taxpayers as required by law, giving the taxpayers notice of the amounts due and the date of delinquency.

That said taxes on the properties herein described not having been paid within the specified time according to law and the notice sent out, became delinquent after the first Monday in March, 1992. That the names of the taxpayers, with the Assessor's Parcel Number upon which taxes have not been paid, with the valuation of the property assessed, and the amount due for the taxes, were entered in the delinquent list of said Eureka County for the taxable year 1991-1992 on the 3rd Monday in March, 1992.

That the said County Treasurer, within 30 days after the first Monday in March, 1992, advertised according to law, in The Eureka Sentinel, a newspaper published for circulation in the Town and

Roll No. 2560	Kenneth M. Roberts Parcel 03-232-01 Lots 1 & 2 Block R, Nevelco Inc. Unit #2 Valuation \$290 Tax \$4.75
Roll No. 2747	Mary T. Schneider Parcel 05-480-17 SW 1/4 Section 7, T29N, R49E M.D.B.&M. Consisting of approximately 40 acres Valuation \$2,140 Tax \$35.00
Roll No. 3052	Unknown Owner Parcel 04-370-13 NE 1/4 Section 25, T32N, R51E M.D.B.&M. Consisting of approximately 40 acres Valuation \$960 Tax \$15.70

County Treasurer and Ex-Officio  
Tax Receiver, Eureka County, Nevada

County of Eureka, State of Nevada, said properties with the name of the owner to whom said property was assessed, and the amount thereon due, with Assessor's Parcel Number, within the time allowed by law, the Tax Receiver or her successor in office to make to the County Treasurer as Trustee for the State and County a deed of the properties.

That said taxes and costs not having been paid as required by law, the Tax Receiver did, in pursuance with said notice, issue a deed to said properties and improvements as heretofore mentioned, together with all and singular the tenements, hereditaments and the appurtenances thereunto belonging or in anywise appertaining. TO HAVE AND TO HOLD and singular the said premises, together with the appurtenances unto said Grantee as Trustee, for said Eureka County, State of Nevada, and her successor in office.



BOOK 270 PAGE 197  
OFFICIAL RECORDS  
RECORDED AT THE REQUEST OF  
Eureka County Treasurer  
94 JUN 22 P2:53  
EUREKA COUNTY, NEVADA  
M.N. REBALIATI, RECORDER  
FILE NO. 153156  
FEE \$ NO  
fee

County Recorder and Auditor  
County of Eureka, State of Nevada

IN WITNESS WHEREOF, I have hereunto set my hand and affixed my official seal at my office in the said County of Eureka, State of Nevada, the day and year hereinabove written.

On the 1st day of June, 1994, personally appeared before me, MICHAEL N. REBALIATI, Recorder and Auditor in and for said County of Eureka, State of Nevada, JOAN SHANGLE, the County Treasurer and Ex-Officio Tax Receiver, known to me to be the person and official described therein and who acknowledged to me that she executed the same freely and voluntarily, and as such County Treasurer and Ex-Officio Tax Receiver and for the uses and purposes therein mentioned.

STATE OF NEVADA )  
: ss )  
County of Eureka )